

GreenlifePro

Put color in your life. Think Green.



DELUXE

Technische kenmerken

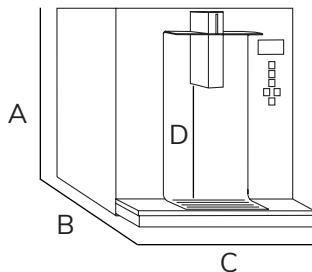

Gewicht	30-32kg
Afmeting (AxBxCxD in mm)	395x535x340x269
Bedieningspaneel	Touch knoppen
Productie	45 l/h
Instant volume koud water	9 liter
Instant volume heet water	15 liter
Koud water temperatuur	3-10°C
Heet water temperatuur	98°C
Capaciteit ijsbank	2kg
Koelgas	R290
Compressorvermogen	1/10 CV
Waterinlaataansluiting	8 mm
CO2 inlaataansluiting	6 mm



Kamertemperatuur



Koud water



Bruisend water



Beveiligingsknoppen heet water

Identificatie onderdelen

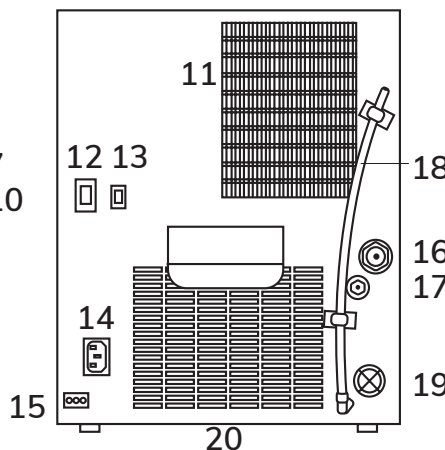
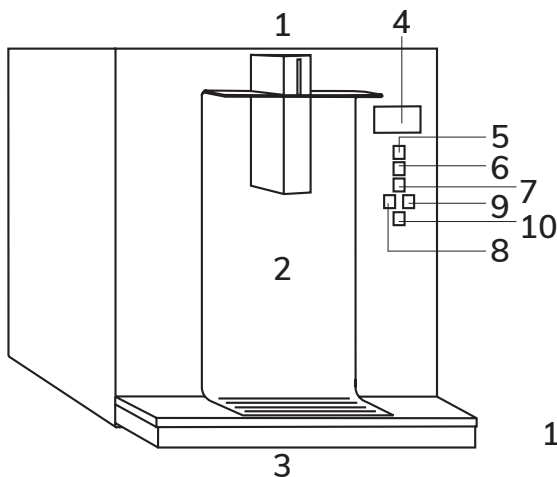

1. Verstelbare spuitmond
2. Stalen front
3. Lekbak
4. Statusweergave
5. Keuzeknop kamertemperatuur
6. Keuzeknop koud water
7. Keuzeknop bruisend water
8. Keuzeknop heet water
9. Beveiligingsknop heet water
10. Menu keuzeknop
11. Ventilatie-uitlaat
12. Aan/uit schakelaar
13. Aan/uit schakelaar heet water
14. Aansluiting voedingskabel
15. Voeding lekbak voor voet optioneel
16. Waterinlaat ijsbank
17. CO2-aansluiting
18. Niveau indicator water v.d ijsbank
19. Wateraansluiting
20. Ventilatie-uitlaat